



D100sw SITE DUMPER



ENGINE	TIER 4F EPA
Model:	KOHLER series KDI 3404 TCRSCR
Type:	Turbo Intercooler
Displacement, No. cylinders:	3,400cc - 4 inline
Injection:	Electronic Control w/ Common Rail
Aftertreatment system:	EGR + DOC + SCR
Cooling:	Air Water, Dry Air Filter
Maximum Power:	122 hp (90 kW)
Adj. Power:	122 hp (90 kW) @ 2,200 rpm
Maximum Torque:	369 lbf.ft (500 Nm) @ 1,400 rpm
Alternator:	12 V - 90 A

4 X 4 DRIVE

Hydrostatic "automotive" transmission with variable displacement pump and variable displacement hydraulic motor with electro-hydraulic control, and reverse gear control on the steering wheel. Electro-hydraulically controlled mechanical gearbox for "working speed" and "road transfer" speed.

Speed:

	4 fwd gears,	4 reverse gears
I°	0 - 2.3 mph	0 - 2.3 mph
II°	0 - 5.9 mph	0 - 2.3 mph
III°	0 - 7.3 mph	0 - 7.3 mph
IV°	0 - 18.6 mph	0 - 7.3 mph

Traction / weight ratio: 48%

AXLES AND WHEELS

Front load-bearing, oscillating ($\pm 6^\circ$) with planetary reduction gears on the wheel hubs.
Rear load-bearing and steering with planetary reduction gears on the wheel hubs and directly flanged gearbox.

Tires: 18-19.5 16PR

ELECTRIC SYSTEM

Battery:

Tier 4F 12 V - 132 Ah
LED road light system, rear working lights.

EQUIPMENT HYDRAULIC SYSTEM

Gear Pump:

Max. low rate: 11.89 gal/min
Max. pressure: 230 bar
2 - elements distributor.

Aluminium heat exchanger for hydraulic oil cooling.

Pressurized closed-circuit intake with oil filter replaceable from the outside.

CAB

Closed cab with heating system designed according to ROPS & FOPS Level II criteria, windows on three sides. Optional cab doors.
Sliding window on cabin door.

180° pivoting driving post. Anatomic seat with flexible suspension and height adjustment, seat belts.
Driving and equipment controls with ergonomic arrangement.
LCD display with reverse camera.

STEERING

Assisted by means of load-sensing power steering with double displacement on 4 steering wheels; steering selection device for: 2 steering wheels, 4 steering wheels - crab steering.



D100sw SITE DUMPER

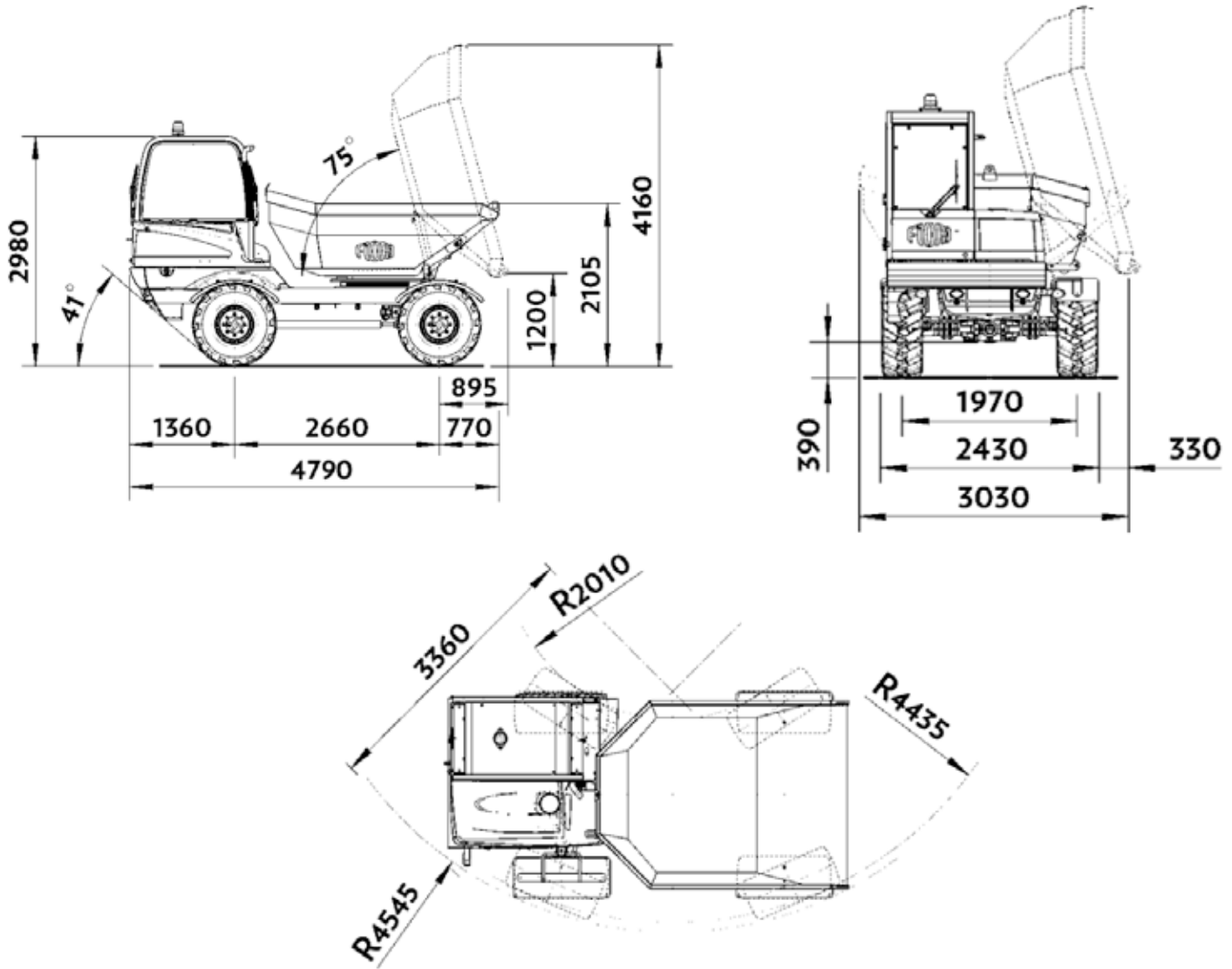

DUMP BODY

Dump body tilting by means of 2 double-acting jack. Orientation over 180° for trilateral unloading by means of "heavy-duty" ball fifth wheel, with hydraulic rotation and automatic locking by means of negative brake.

Struck capacity: 4.84 cu yd
 SAE heaped capacity: 6.80 cu yd

WEIGHTS

Operating weight: 12,566 lb
 Max. gross weight: 35,274 lb
 Load-carrying capacity: 22,046 lb

BRAKES

Internal oil-bath disc service and emergency brakes acting on the 4 wheels, activation with pump on independent dual circuit.

Negative-type parking brake with internal oil-bath discs on the rear axle and electro-hydraulically controlled release.

SERVICE REFILL CAPACITIES

Fuel tank: 25.1 gal
 Total hydraulic system capacity: 27.7 gal
 Engine oil: 17.63 lb