

---

# TA 230 Litronic

---

## LIEBHERR

Articulated Dump Truck



**Generation**

8

**Empty Vehicle Weight**

24,600 kg

**Engine**

265 kW / 360 HP

Stage V

Tier 4 Final

Stage IIIA (compliant)

Non-regulated

**Dump Body Capacity**

18.1 m<sup>3</sup>

**Payload**

28,000 kg

## Performance

Powerful Drawbar Pull  
for Excellent Off-Road Use

## Economy

Short Cycle Times Result  
in Maximum Efficiency

## Reliability

Robust Construction and  
Quality for Durability

## Comfort

Ergonomic Excellence – Superior Cab Design  
for Operator Comfort and Wellbeing

## Maintainability

Service Every Step of the Way –  
Simple, Fast and Reliable





## TA 230 Litronic

<b>Empty Vehicle Weight</b>	<b>Dump Body Capacity</b>
24,600 kg	18.1 m <sup>3</sup>
<b>Engine</b>	<b>Payload</b>
265 kW / 360 HP	28,000 kg
Stage V	
Tier 4 Final	
Stage IIIA (compliant)	
Non-regulated	

# Performance

---



## Powerful Drawbar Pull for Excellent Off-Road Use

The Liebherr dump truck was developed for maximum productivity. Its powerful drivetrain enables more material movement in less time.

# Maximum Performance

## Drive Performance

Under the bonnet of the newly developed Liebherr TA 230 is a 6-cylinder construction machinery engine with a displacement of 12 l, developing 265 kW / 360 HP (at 2,100 rpm). Thanks to its powerful engine and efficient drivetrain, the TA 230 generates enormous drawbar pull on difficult terrain and challenging gradients. At full speed, the machine can reach speeds of up to 57 km/h (up to 16 km/h in reverse).

## Braking Performance

In addition to hydraulic multi-disc brakes on all axles, the TA 230 also features a zero wear upstream braking system. This comprises an engine brake and a hydrodynamic primary retarder. The continuous-operation brake is activated automatically as soon as the brake pedal is pressed, it is highly controllable, protects the components and provides additional safety due to its significant deceleration on gradients.

# Simplified Maintenance Concept

## Designed for Off-Road Use

The interaction of balanced weight distribution, permanent 6 x 6 all-wheel drive, solid, flexible axle mounting and large bank angle as well as its high ground clearance enable the TA 230 to deliver unbeatable performance on uneven terrain. Despite challenging ground conditions, the new Liebherr dump truck delivers traction and control in all situations. A selection of tyres can be used to further tailor the machine to specific applications.

## Automatic Traction Control

The actively controlled inter-axle differential locks mean that the Liebherr TA 230 has automatic traction control. As soon as one axle experiences wheelspin, it is decelerated and the traction is intelligently redistributed to the other axles. In addition to maximum forward drive, this effect reduces the power requirement and therefore fuel consumption.



## Powerful Components

- Powerful and robust construction machinery motor for continuous use at full load
- Automatic 8-speed powershift transmission for excellent power transfer
- Power shifting inter-axle differential locks for permanent traction



## Efficient Loading

- Innovative weighing system, fitted as standard, displays the payload weight during the loading process
- Optional loading traffic light system – to make the load status visible externally
- Machine productivity levels shown on display and through LiDAT
- Protects the machine components and reduces fuel consumption



## Improved Dump Box

- Large, solidly designed dump box
- Straight dump box front and low side edge for easier loading
- Long dump box chute to prevent material loss
- Optional dump box cladding and dump box heating system available

# Economy

---



## Short Cycle Times Result in Maximum Efficiency

Thanks to its robust design and short cycle times, the TA 230 is an excellent investment. It can withstand the rigors of hard and continuous work whilst delivering excellent productivity. The perfect combination for a successful future.

## Maximum Efficiency

### Maximum Readiness

The Liebherr TA 230 travel drive increases efficiency significantly. Short cycle times due to maximum efficiency in acceleration, transport and deceleration performance deliver enormous handling capacity and therefore maximum economy.

### Powerful Construction Machinery Engine

The Liebherr D956 diesel engine provides power combined with fuel efficiency. The engine design, injection system and engine management system are perfectly coordinated with each other to achieve top performance. The combustion chamber geometry has been enhanced to improve the fuel combustion process, whilst a more efficient turbo charging process has been developed and engine friction losses minimised. When combined with the company's own injection and engine control systems, the result is minimal generation of soot particles.

## Increased Productivity

### Efficient Management

LiDAT, Liebherr's data transfer and location system, enables contractors to manage, monitor and control their entire fleet efficiently in terms of machine data recording, data analysis, fleet management and service. All the main machine data can be viewed at any time using a web browser. The integral weighing system in the TA 230 also enables you to access weighing data and therefore assess the productivity of your Liebherr dump truck. A maintenance report is also available, as for your other Liebherr machines.

### Smart Gear Selection

The Liebherr TA 230 combines maximum efficiency with high loading capacities. The automatic gear selection enables the machine to adjust automatically to its current speed and load so that it always has the optimum torque and fuel consumption level. The machine therefore automatically reduces its fuel consumption per tonne of transported material.



### Liebherr-SCRFilter

- Emissions treatment system for stage V combines DOC catalytic converter, SCR catalytic converter and SCR-coated particulate filter
- The DOC catalyst requires no maintenance and the coated particulate filter can be actively regenerated by the machine



### Simple Transport

With its wide tyres, tailgate and side mirrors folded in (this requires no tools), the Liebherr TA 230 has an overall width of less than 3 m and can be transported without the need for a special permit. This means that there are no complicated and expensive logistics involved.



### Flexible in Action

- The design takes account of a wide range of operating scenarios for rapid transfers between sites
- Also ideal for specialised jobs in industry, tunnels, etc.

# Reliability

---



## Robust Construction and Quality for Durability

The Liebherr TA 230 gives maximum performance even in the most challenging conditions. Specially developed components, sophisticated technology and a high quality build guarantee maximum reliability and availability.



## High Machine Availability

### Durable and Powerful

Liebherr has decades of experience in the development, design and production of components. When coordinated perfectly with each other, they guarantee maximum performance and reliability. The new TA 230 has been developed and designed on the back of extensive test trials to ensure the resilience and quality of the component parts time after time. Even in the most adverse of conditions, the TA 230 still satisfies Liebherr's high quality standards.

### Work Without Interruption

The diesel particulate filter is regenerated during operation by an active regeneration process, enabling you to work without any interruption. The long intervals between the regeneration cycles increase productivity, save fuel and reduce running costs.

## Greater Safety

### Assistance Systems

Modern operator assistance systems provide support and enhance productivity and safety in operation. In addition to a hill start assistant, the TA 230 also has a speed maintenance assistant. Furthermore, the limit position dampening of the dump box cylinders can be activated or deactivated at the touch of a button (hard stop). If work is being carried out in an area with critical height, the dump box lift height can be limited.

### Robust Construction

All structural components and load-bearing parts were developed during the design phase to provide extreme robustness and rigidity. FEM simulations and real-life site conditions at the test center and on customer sites were vital in the component developmental phase. They guarantee that all applied forces will be absorbed perfectly to ensure that the TA 230 will exceed customer expectation with its reliability and long service life.



### QPDM – Quality and Process Data Management

- QPDM allows production data to be logged, documented and evaluated
- Automation of documentation and test specifications
- Ability to handle large quantities and maintain uniform high quality



### Safe Working Environment

- Welded cab structure combined with the floor plate and cab mount form a stable ROPS for maximum accident protection
- All-round tinted safety glass
- Quiet, low vibration working environment created by the use of special materials and specially developed cab suspension mounts



### Development and Demonstration Centre

- Partly autonomous long-term load tests on the TA 230 in the only testing centre of its kind in Europe
- Structural test with a wide range of loads (potholes, bumps, inclines, etc.)
- Specially designed poor surface track with 12 function lanes as well as gravel and soil surfaces

# Comfort

---



## Ergonomic Excellence – Superior Cab Design for Operator Comfort and Wellbeing

The newly developed cab on the TA 230 with standard roll-over protection system (ROPS) provides the perfect environment for comfort, concentrated and productive work. Thanks to large all-round glass windows and the short, angled bonnet, the operator has perfect visibility of the machine's driving, working and articulation areas. The ergonomic control elements and touchscreen display with integrated rear-view camera simplify operation and extend visibility at the rear of the machine.

## First-Class Cab

### Feel-Good Cab

The workstation in the TA 230 has a roomy design to keep operators feeling good even on long, hard working days. Various storage trays, storage areas, cup holders and the standard air-conditioned compartment deliver additional space and enable the operator to store personal items safely. The sound-insulated cab and its visco-elastic mounts produce a significant reduction in noise level inside the cab. The pressurised ventilation and air-conditioning system with improved cooling capacity delivers a dust-free environment and a pleasant temperature at all times.

### Operator Seats

As for other Liebherr machines, there is a range of high quality, modern, robust operator seats available for the TA 230. In addition to extensive adjustment facilities, the Comfort seat features pneumatic suspension with automatic weight adjustment, a lumbar support, seat heating and passive seat air conditioning. This enables operators to work without fatigue throughout long days whilst protecting their backs.



### Everything at a Glance

- Operator's cab with large areas of glass for excellent visibility of the front, sides and articulation area
- Standard rear window heating
- Electrically adjusted and heated rear mirror, optional

## Comfortable Operation

### Speed-Dependent Steering

The adaptive steering system in the TA 230 continuously adjusts the transmission ratio of the steering movements to the current speed. This makes easy, precise manoeuvring possible at low speeds. Furthermore, more pronounced steering movements are required at high speeds to manoeuvre the machine. This ensures you can move around your site in safety and comfort at all times.

### Liebherr Control Concept

Liebherr delivers an operator-focused control system which uses the same logic in all machine classes and generations. Clarity, ergonomics and safety are the principles we follow in the design phase. That means we avoid time-consuming re-familiarisation phases and allow the operator to work efficiently in his machine straight away.



### Working Area Lighting

- Superb illumination of the roadway using LED headlights with integrated highbeam light
- Extra powerful LED headlights on the front of the cab to illuminate the entire working area
- Headlights on the mudguards and rear of the dumper truck to safely illuminate the manoeuvring area at night
- Optional access ladder lighting



### Intuitive Control

- Display of the machine data and camera image on the 9-inch indicating unit with touchscreen and direct access via menu bar
- Rear view monitoring with camera as standard
- Mobile phone holder and USB charging sockets as standard
- DIN installation frame to install your own devices (for example CB radios, etc.)

# Maintainability

---

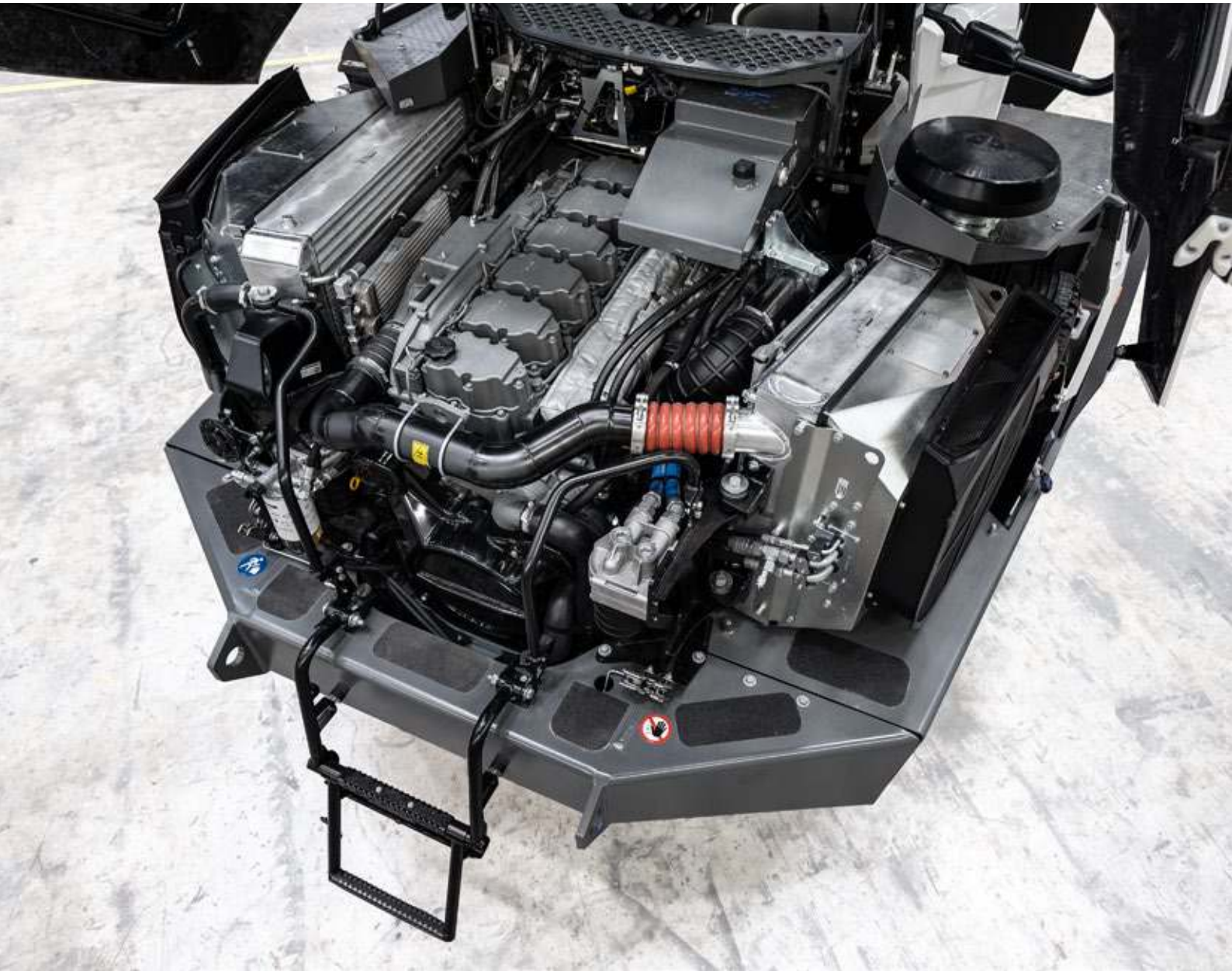

## Service Every Step of the Way – Simple, Fast and Reliable

The TA 230 is not only powerful, robust, precise and efficient, but also features fast, simple and safe maintenance. This minimises the construction machine's costs and down times.

## Simplified Maintenance Concept

### Service-Based Machine Design

The electro-hydraulic bonnet and integral access ladder with non-slip steps provides safe, clear access to the entire engine compartment. The service points are clearly visible and easy to reach. All maintenance work can be carried out conveniently and safely from a standing area. A solid step provides easy access to the windshield. Sturdy handrails and a surrounding roof rail provide a secure hold for cleaning and maintenance.

### Smart Machine Check-Up

When the TA 230 is started at the beginning of each day, it automatically runs through a series of tests during which various levels are monitored. The levels of the engine and hydraulic oil, coolant and the level of grease in the central lubrication system are all checked. This increases the reliability of the components and reduce the daily set-up time for the operator. Any messages are shown on the display.

## Your Competent Service Partner

### Partnership with Efficient Service

With every Liebherr dump truck, not only has the customer decided to buy a premium product, but also to enter a solid, long term partnership. An extensive worldwide service network combined with a state-of-the-art central parts facility ensures excellent service and fast spare part deliveries. This guarantees direct communication and fast support around the clock when necessary.

### Competent Liebherr Service

Extensive expertise ensures that all service and maintenance work is complete with first class quality. This makes a major contribution to the availability and profitability of the machine. All Liebherr service partner personnel receive regular advanced training. They have extensive knowledge to carry out service work quickly and safely and have access to the expertise available at the factories at all times.



### Braking System

- Maintenance-free continuous-operation brake, consisting of retarder and engine brake
- Automatic retarder system for maximum control
- Braking capacity distributed to all axles
- Long service life for hydraulic multi-disc brakes

### Central Lubrication System

- Standard central lubrication system provides automatic lubrication\*
- Sensor-supported tank notifies the operator if the tank content falls below the minimum level
- Sturdy housing and easy access for filling up

\* country-dependent

### Practical Tool Compartment

- Storage compartment for toolbox and grease cartridges, with optional pull-out drawer
- Easily accessible and safely stowed
- Lockable

# Articulated Dump Truck TA 230 Litronic Overview

## Simplified Maintenance Concept for Maximum Productivity

- Service-based machine design with easy access to the maintenance points
- Smart machine check-up
- Central lubrication system, sensor-controlled\*
- Storage compartment for toolbox and grease cartridges
- Qualified, experienced specialists for competent advice
- 24 / 7 Spare parts service with 24 hour deliveries

## Superior Technology for Highest Economy

- 6-cylinder Liebherr construction machinery engine with emissions Stage V, Tier 4 Final, Stage IIIA (compliant) and Non-regulated
- LiDAT - Liebherr's information system for efficient fleet management and evaluation

## Perfect Combination for Highest Possible Performance

- Permanent 6 x 6 all-wheel drive
- Automatic 8-speed powershift transmission
- Continuous-operation brake (engine brake, hydrodynamic primary retarder), zero wear
- Power shifting inter-axle and lateral differential locks for permanent traction
- Innovative weighing system to show the current payload
- Optional loading traffic light system
- Large, solidly designed dump box
- Optional dump box tailgate
- Optional dump box cladding and heating

\* country-dependent





## Ergonomic Operator's Work Station for Maximum Comfort

- Cab with large glass areas for improved visibility
- Rear window heating
- Electrically adjusted and heated rear mirror, optional
- Sound-insulated cab
- Sealed pressurised ventilation
- 9" large colour touchscreen
- Rear monitor
- Convenient radio control with hands-free kit
- Mobile phone holder and USB charging sockets
- Additional DIN installation frame
- Automatic air-conditioning system
- High quality operator's seats in a range of versions
- Air-conditioned compartment
- LED dipped headlights with integral high-beam light
- Extra powerful LED headlights to illuminate the working area
- Manoeuvring lights for reversing
- Optional access ladder lighting

## Excellent Machine Concept for Maximum Reliability

- Painstakingly developed structural components
- Robust construction made of high-tensile steel
- Partly autonomous long-term load tests at the only testing centre of its kind in Europe
- ROPS/FOPS cab structure
- Tinted safety glass
- Hill start assistant
- Speed maintenance assistant
- Activation and deactivation of limit position dampening on the dump box cylinders
- Height limitation

# Technical Data



## Diesel Engine

<b>Rating per ISO 9249</b>	265 kW (360 HP) at 2,100 RPM
<b>Model</b>	Liebherr D956
<b>Type</b>	6 cylinder in-line
<b>Bore / Stroke</b>	130 / 150 mm
<b>Displacement</b>	12.0 l
<b>Engine operation</b>	4-stroke diesel Common-Rail Turbo-charged and after-cooled Reduced emissions
<b>Air cleaner</b>	Dry-type air cleaner with pre-cleaner, primary and safety elements
<b>Electrical system</b>	
<b>Voltage</b>	24 V
<b>Batteries</b>	2 x 12 V / 180 Ah
<b>Alternator</b>	Three-phase current 28 V / 140 A
<b>Starter</b>	6.5 kW
<b>Stage V</b>	
<b>Harmful emissions values</b>	According to regulation (EU) 2016/1628
<b>Emission control</b>	Liebherr-SCRFilter technology
<b>Tier 4 Final</b>	
<b>Harmful emissions values</b>	In accordance with 40CFR1039 (EPA) / 13CCR (CARB)
<b>Emission control</b>	Liebherr-SCR technology
<b>Stage IIIA (compliant 97/68/EG)</b>	
<b>Harmful emissions values</b>	In accordance with ECE-R.96 Power Band H
<b>Emission control</b>	Liebherr-EGR technology
<b>Non-regulated</b>	Only for selected markets
<b>Emission control</b>	Without Liebherr-EGR technology



## Cooling System

<b>Diesel engine</b>	Water-cooled Compact cooling system consisting of: cooling units for water, hydraulic oil, fuel and climate condenser, charge the air with stepless thermostatically controlled fan. Foldable radiator allowing easy cleaning
----------------------	---



## Drive Train

<b>Transmission</b>	Automatic powershift transmission with torque converter and converter bypass clutch, 8 forward and 4 reverse speeds, integral distributor gear box with load-switchable inter-axle differential lock
<b>Speeds</b>	57 km/h forward 16 km/h backwards
<b>Drive train</b>	6 x 6 permanent all-wheel drive with automatic inter-axle differential lock, switchable lateral differential lock on all axles (can be activated manually)



## Axles

<b>Front axle</b>	External planetary axle with load-switchable differential lock, four-point suspension with hydro-pneumatic spring cylinders, maintenance-free bearings
<b>Rear axles</b>	External planetary axle with load-switchable differential lock, four-point suspension, maintenance-free bearings



## Brakes

<b>Continuous-operation brake system</b>	Electronically controlled continuous-operation brake system consisting of engine brake and hydro-dynamic primary retarder
<b>Operating brake*</b>	Hydraulic multi-disc brakes, 2 brake circuits acting on all wheels
<b>Parking brake*</b>	Disc brake with hydraulic spring accumulator cylinder acting on rear axles

\* Brake system complies with standard DIN EN ISO 3450



## Steering

<b>Design</b>	Electro-hydraulic, speed-dependent steering, 2 dual-action cylinders combined with articulated steering
<b>Steering angle</b>	± 45°
<b>Steering wheel turns from stop to stop</b>	4.5



## Hydraulic System

<b>Hydraulic circuit</b>	On-demand flow control, engine driven axial piston pump, wheel driven piston pump for emergency steering
<b>Max. flow</b>	354 l/min.
<b>Max. pressure</b>	24 MPa
<b>Operation</b>	
<b>Dumping</b>	Dump body operating lever with automatic engine rpm increase
<b>Filtration</b>	Return filter (10 µm), integral magnetic rod



## Filling Quantities

<b>Fuel tank</b>	365 l
<b>Urea tank (only Stage V / Tier 4 Final)</b>	46 l
<b>Cooling system</b>	112 l
<b>Engine oil (incl. filter)</b>	42 l
<b>Hydraulic tank</b>	168 l
<b>Gear oil (replacement volume)</b>	50 l
<b>Axles</b>	105 l



## Tyres

Standard tyres	23.5R25
Design	Earthmoving radial, tubeless
Wide base tyres	750/65R25

## Dump Body Capacity

<b>Volume</b>	
Swept	13.6 m <sup>3</sup>
Stacked 2:1	17.5 m <sup>3</sup> according to ISO 6483
With flap swept	13.9 m <sup>3</sup>
With flap stacked 2:1	18.1 m <sup>3</sup> according to ISO 6483
<b>Payload</b>	28,000 kg
<b>Dumping time</b>	12 s
<b>Lowering time</b>	8 s
<b>Dump angle</b>	70°

## Operating Weight

<b>Axle loads (unladen)</b>	
Front axle	14,100 kg
Middle axle	5,300 kg
Rear axle	5,200 kg
Gross weight	24,600 kg
<b>Axle loads (with maximum load)</b>	
Front axle	16,300 kg
Middle axle	18,200 kg
Rear axle	18,100 kg
Gross weight	52,600 kg

## Complete Machine

<b>Type</b>	High-strength steel plates at highly-stressed points for the toughest requirements. Complex and stable mountings of dump body and cylinder
<b>Hydraulic cylinders</b>	Hydraulic cylinders with special sealing and guide system and shock absorption which can be activated and deactivated at the touch of a button
<b>Bearings</b>	Sealed, low maintenance
<b>Lubrication**</b>	Liebherr automatic central lubrication system for front and rear of the truck
<b>Noise emission</b>	
ISO 6396 (Stage V)	72 dB(A) = L <sub>PA</sub> (inside cab)
2000/14/EC	109 dB(A) = L <sub>WA</sub> (surround noise)

## Cab

<b>Cab</b>	Elastically mounted, noise-insulated, integral ROPS/FOPS structure, seal pressurised ventilation system, fresh air filter with initial filter, additional recirculated air filter, operator's cab with excellent visibility to the front and side and in the articulation zone, tinted safety glass all-round, sliding window on the right, rear window heating, wash / wipe system with multi-setting intermittent function for windscreen, wide roll-down sun visor for windscreen, steering column can be swivelled and telescoped with dirt seal, grab handles for the safety of the operator and passenger, convertible footrest, lots of storage trays with removable inserts, tilt-and-turn drawer, spectacles holder, smartphone holder with UBS interface charging facility, air conditioned cooling compartment with adjustable nozzle, roof casing with enhanced water flow, surrounding roof railing
<b>Operator's seat Basic (Option)**</b>	Mechanical operator's seat with adjustable armrests, headrest, lap belt with belt buckle monitor, additional instructor seat
<b>Operator's seat Comfort</b>	In addition to operator's seat basic: pneumatic suspension with automatic weight adjustment, lockable longitudinal horizontal suspension, adjustable seat cushion inclination and length, adjustable suspension stiffness, pneumatic lumbar vertebrae support, seat heater and passive seat climatization with active coal
<b>Operator's seat Premium (Option)</b>	In addition to operator's seat comfort: active electronic weight adjustment (automatic readjustment), additionally locking lateral horizontal suspension, pneumatic low frequency suspension
<b>Operation and displays</b>	Large high-resolution operating unit with touchscreen control, self-explanatory, numerous settings, control and monitoring options, e.g. air conditioning control, fuel consumption, machine parameters, positions of control elements for intuitive use in the front and top comfort area
<b>Air-conditioning</b>	Automatic air-conditioning, recirculated air function, fast de-icing (Defrost) and demisting at the press of a button, air vents can be operated via a menu; airflow can be directed at door and side windows, recirculated air and fresh air filters can be easily replaced, initial filter can be cleaned; all filters accessible from outside; heating-cooling unit, designed for extreme outside temperatures, sensors for solar radiation, inside and outside temperatures
Refrigerant	R134a
Global warming potential	1,430
Quantity at 25 °C	1,000 g
CO <sub>2</sub> equivalent	1.43 t
<b>Vibration emission*</b>	
Hand / arm vibrations	< 2.5 m/s <sup>2</sup>
Whole-body vibrations	Average load
	1.4 × a <sub>w,eqx</sub> 1.4 × a <sub>w,eqy</sub> 1.4 × a <sub>w,eqz</sub>
Loading	0.29      0.41      0.24
Operating with load	0.64      0.89      0.67
Operating without load	0.82      1.02      0.81
Unloading	0.49      0.42      0.30
Measuring inaccuracy	According with standard EN 12096:1997

\* for risk assessment according to 2002/44/EC see ISO/TR 25398:2006

\*\* country-dependent

# Dimensions

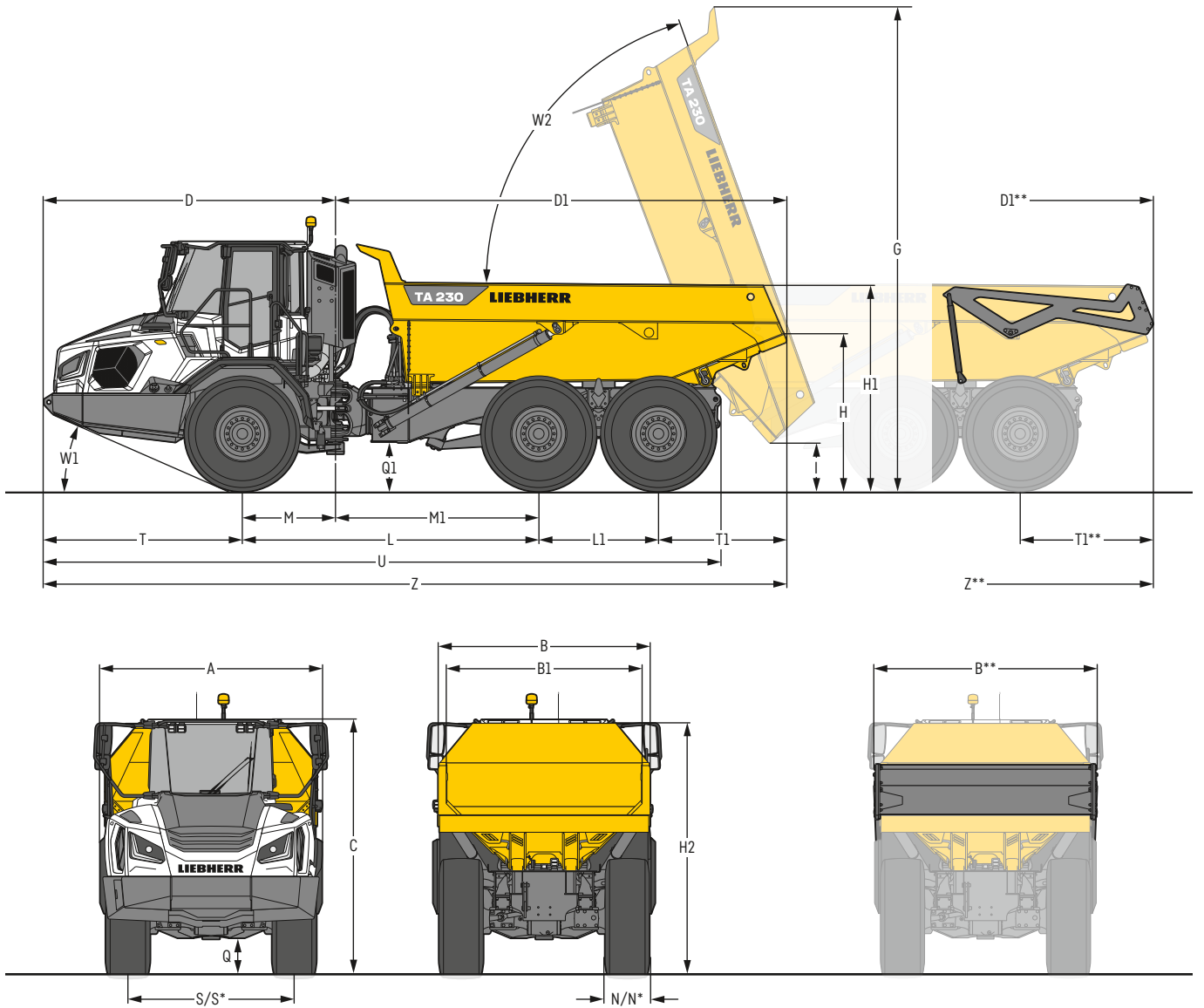

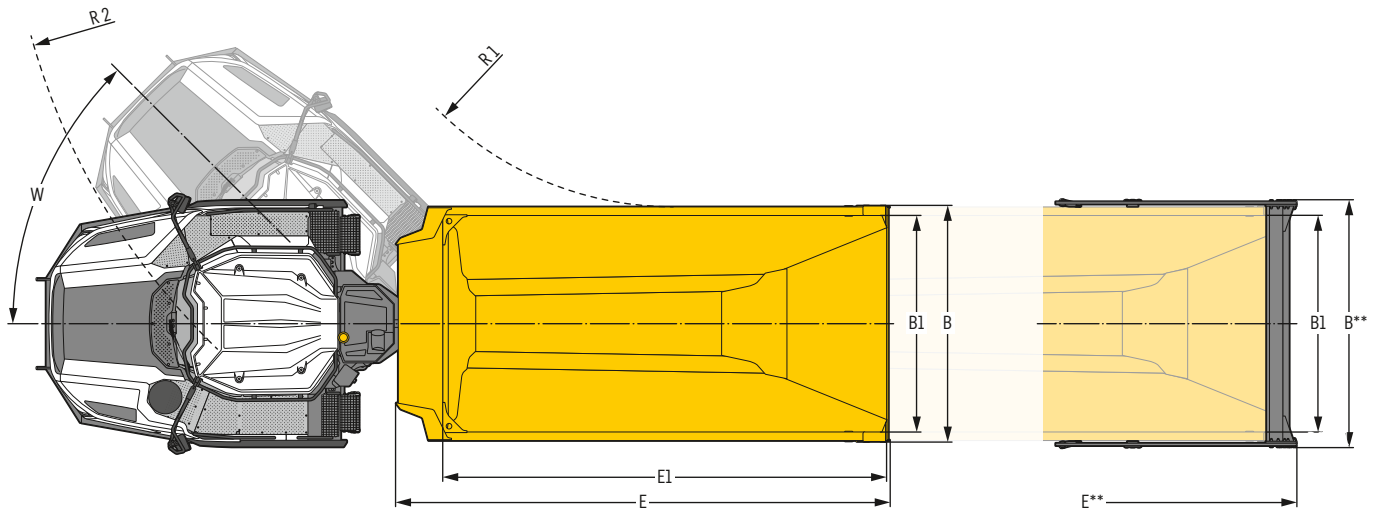

	mm
A	2,996
B	2,860
B**	2,996
B1	2,630
C	3,395
D	4,070
D1	6,295
D1**	6,370
E	5,995
E**	6,070
E1	5,390
G	6,670
H	2,100
H1	2,810
H2	3,345
I	575
L	4,140
L1	1,670
M	1,300

	mm
M1	2,840
N	602
N*	738
Q	425
Q1	595
R1	4,090
R2	8,055
S	2,245
S*	2,225
T	2,770
T1	1,785
T1**	1,860
U	9,445
W	45,0°
W1	23,4°
W2	70,0°
Z	10,365
Z**	10,440

\* = with wide base tyres

\*\* = with tailgate

# Equipment

## Complete Machine

Axles, powershift mechanism 100%	•
Operating brake, 2 brake circuits	•
Wide base tyres 750/65R25, Michelin XAD	+
Wide base tyres 750/65R25, Trelleborg	+
Continuous-operation brake, electronically controlled (zero wear)	•
Travel light LED	•
Rock tyres 23.5R25, Michelin X TRA DEFEND	+
Hood opening, electro-hydraulic	•
Main battery switch for electrical system	•
Full-cover tailgate	+
Tailgate with bottom hinge	+
Wiggins coupling for fuel	+
Ladder access to engine	•
Dump box liner	+
Dump box heating system (exhaust gas driven)	+
Reversing lights on mudguards, both sides, LED	+
Traction control automatic	•
Service doors, lockable	•
Standard tyres 23.5R25, Michelin XADN	+
Standard tyres 23.5R25, Trelleborg E3	•
Auxiliary heating, adjustable (week time switch)	+
Tool equipment, extended	+
<b>Lubrication</b>	
Lubricants and operating fluids standard (-20 °C to +40 °C)	•
Automatic central lubrication system, front and rear of truck*	•
<b>Special coating</b>	
Special paint for dump box	+
<b>Monitoring</b>	
Rear view monitoring with camera	•

## Hydraulic System

Pressure test fittings	•
Hydraulic oil filter with integrated microfilter	•
Liebherr hydraulic oil from -20 °C to +40 °C	+
Liebherr hydraulic oil, biologically degradable	+
Liebherr hydraulic oil, specially for warm or cold regions	+

## Diesel Engine

Fuel anti-theft device	•
Liebherr particle filter (Stage V)	•
Preheating fuel	+

## Cab

Storage compartments	•
Control unit	•
Traffic light loading indicator in cab	+
Lighting for cab access, both sides, LED	+
Roof railing, surrounding	•
Operator's seat Basic*	+
Operator's seat Comfort	•
Operator's seat Premium	+
Fire extinguisher	+
Rear window heating	•
Fuel consumption indicator	•
Automatic air conditioning	•
Cool compartment, air-conditioned	•
Steering column can be swivelled and telescoped with dirt seal	•
LiDAT, vehicle fleet management	•
Emergency off switch in cab and cab access	+
On-board scales	•
Radio Comfort	+
Preparation for radio installation	•
ROPS cab protection	•
Back-up alarm, acoustic, can not be switched off	+
Electrically adjustable and heated rear-view mirrors	+
Standard rear mirror	•
Amber beacon, on cab, 1 piece	+
Tinted windows	•
Windshield wiper, entire windscreen	•
Slipcover for operator seat	+
Smartphone holder with USB interface charging facility	•
Sun blind	•
First-aid box	+
Cigarette lighter	•

• = Standard, + = Option  
\* = country-dependent

Options and /or special equipment, supplied by vendors other than Liebherr, are only to be installed with the knowledge and approval of Liebherr in order to retain warranty.

## Liebherr-Hydraulikbagger GmbH

Liebherrstraße 12 · 88457 Kirchdorf/Iller, Germany · Phone +49 7354 80-0 · Fax +49 7354 80-72 94  
info.lhb@liebherr.com · www.liebherr.com · www.facebook.com/LiebherrConstruction